

Tufline® Lined Accessories

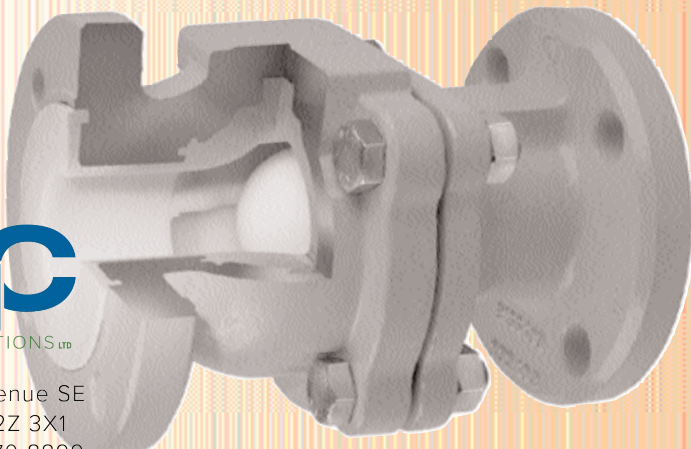
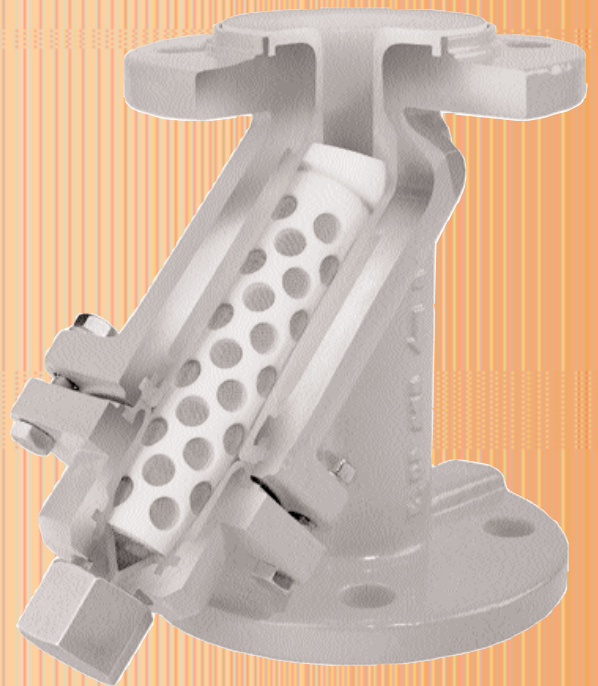
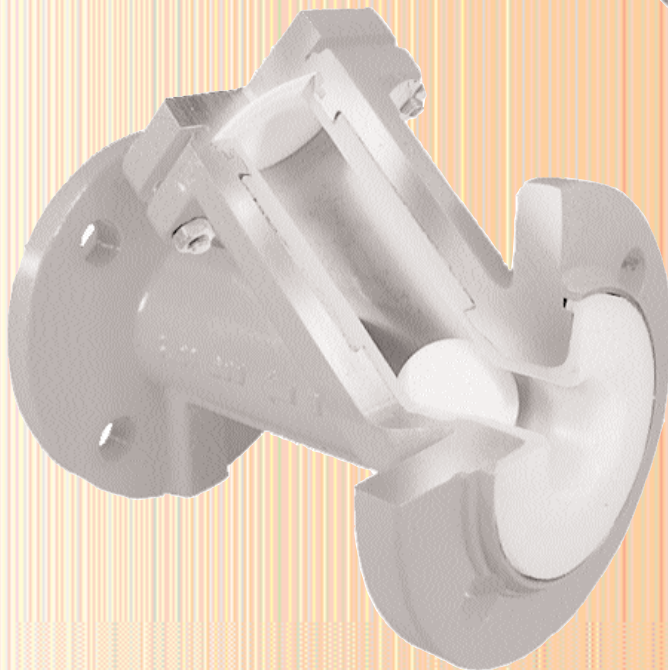
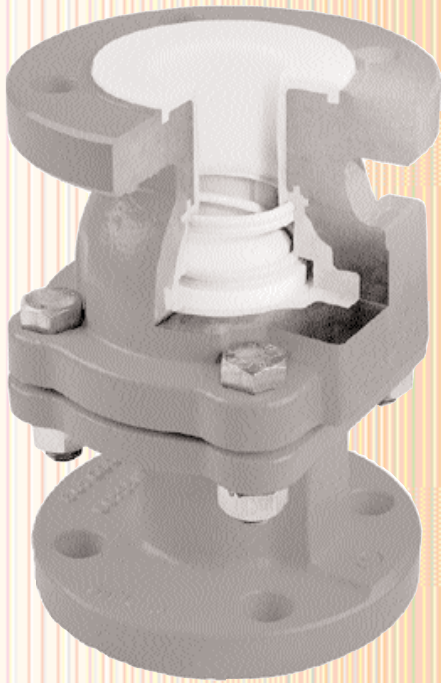

PRODUCT SOLUTIONS™

110, 3160 118 Avenue SE

Calgary, AB T2Z 3X1

TOLL FREE: 888 770 8899

MAIN: 403 295 3114

EMAIL: ngcsales@ngc-ps.com

WEB: ngc-ps.com

XOMOX®
Process Valves & Actuators

For your most demanding applications . . .

Xomox worldwide capabilities pay off for you. With facilities in a dozen countries around the world, Xomox offers unique capabilities for global sourcing of the latest technologies, the best materials, and the most sophisticated manufacturing techniques. Your Xomox team turns these resources into problem solving valves for your most demanding applications.

Problem-solving and cost-cutting valves.

Xomox valves reduce downtime, cut maintenance costs, and provide longer service life. Your long-term cost of valve ownership is dramatically reduced.

More information.

For a listing of Xomox Regional Offices, and Authorized Distributors, visit our web site www.xomox.com.

Tuflin® Lined Accessories:

- Wafer Swing Check Valves
- 45° Ball Check Valves
- Ball Check Valves
- Piston Check Valves
- Poppet Check Valves
- Sight Flow Indicators
- Basket Filters
- Strainers
- Tank Bottom Valves
- PTFE Clamp Valves
- Short Face-To-Face Ball Valves

Lining materials and methods.

The choice of lining materials and the method of lining are critical.



We begin with the purest fluorocarbon materials.

To assure lining integrity and maximum corrosion resistance, Xomox uses only PFA and FEP fluorocarbons.*



* Poppet Check Valves are available with polypropylene and PVDF liners in addition to PFA.

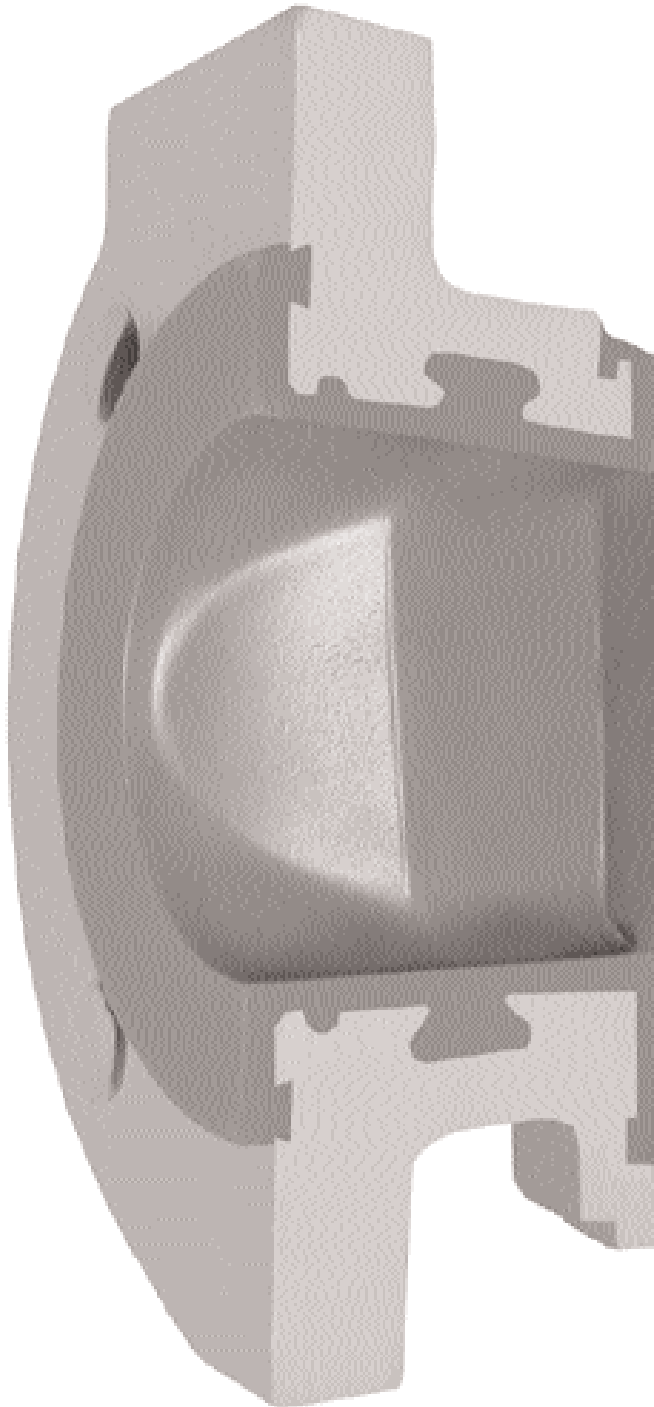

Locked-in linings.

Tuflin Lined Accessories have cast dovetail recesses and machined grooves that lock the lining to the body casting.

Blow-out or liner collapse are virtually impossible.

PFA

PFA is the standard lining material for all Tuflin Lined Accessories.

PFA is a fluoropolymer with extended temperature limits. It is a copolymer that combines the carbon-fluorine backbone of fluorocarbons with a perfluoroalkoxy side chain.

PFA offers a variety of attributes and benefits:

- Handles a wide range of fluids
- Chemically inert
- Heat resistant
- Weather resistant
- Stress-cracking resistant
- Negligible moisture absorption
- Better sealing and wear resistance between parts - because it is moldable and machinable to close tolerances.
- PFA is a true thermoplastic and is melt processible, so it can be locked to the valve components. Blow-out or liner collapse are virtually impossible.

Physical Properties

Property	PFA Perfluoroalkoxy	
	ASTM method	Value
Melting point	-	575° - 590°F
Tensile strength @ 73°F	D638	3,800 psi
Elongation @ 73°F	D638	300%
Flexural modulus @ 73°F	D790	100,000 psi
Impact strength @ 73°F	D256	No break
Coefficient of linear thermal expansion per °F	D696	6.7 x 10 ⁻⁵ (70° to 212°F)
Flammability	D635	Nonflammable
Weather and chemical resistance	-	Excellent

070 Wafer Swing Check Valve

Sizes 3 through 12 inch, ANSI Class 150

Consult factory for Class 300 applications.

Fully lined wafer swing check valves are ideal for use in totally lined piping systems or to replace costly high alloy valves in corrosion applications. The valve can be mounted horizontally or vertically with upward flow.

Tufline wafer swing check valves are of two piece construction with only one moving part. Integral hinge pins fit into the valve body recess. There are no springs or pins to corrode or wear.

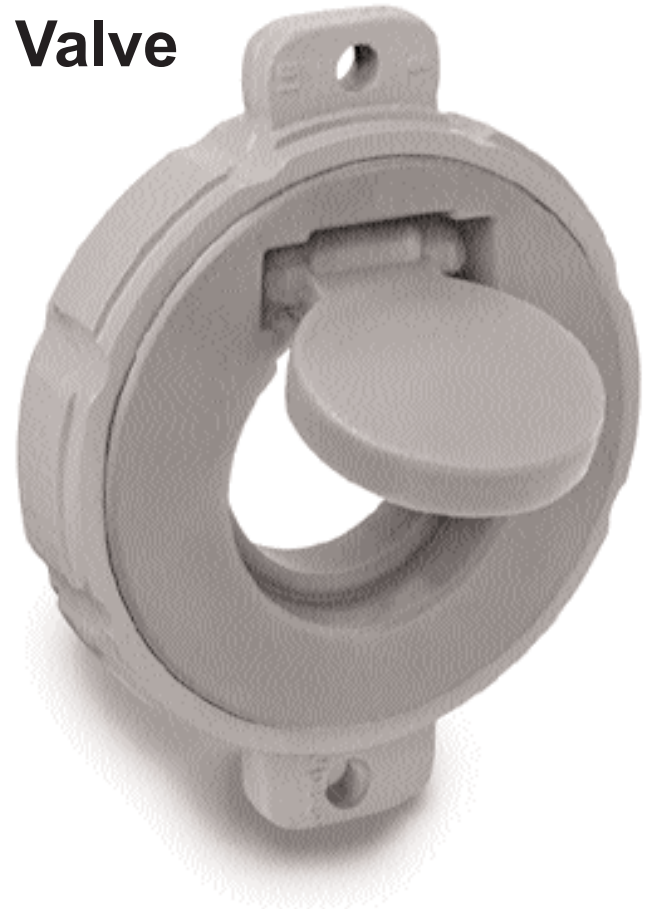

Pressure-Temperature Ratings

(Valves with PFA linings)

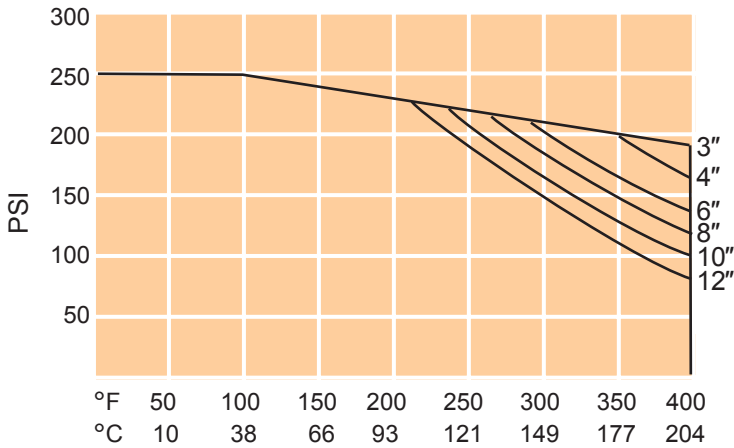

Materials Of Construction

Body	PFA lined ductile iron
Disc	PFA lined ductile iron

Maximum allowable $\Delta P = 250$ psi.

Leak Rate

ΔP (psi)	Leak Rate
0 - 40	5 - 10 cc/min.
41 - 74	3 - 5 cc/min.
75 and over	0

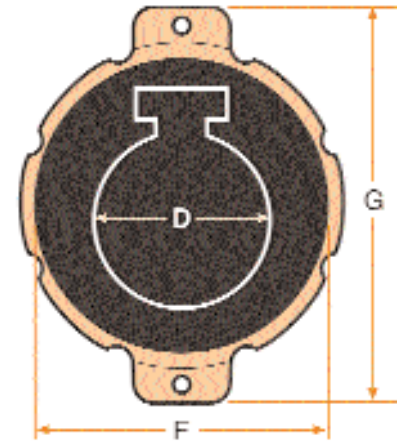
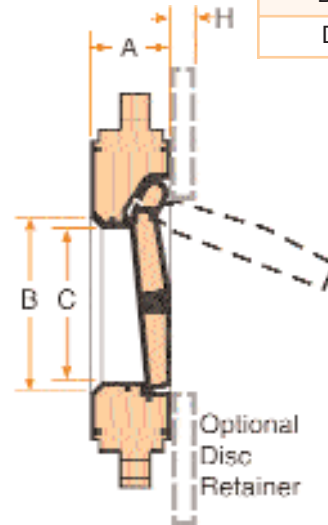

Dimensions (inches)

Size	A	B	C	D	F	G	H	Wt.lbs.	Mating Pipe I.D.*		Cv Factors
									Min.	Max.	
3	1.81	2.28	1.65	2.20	5.04	7.00	.375	7	2.88	3.23	100
4	1.81	3.31	2.56	3.20	6.38	8.88	.375	13	3.74	4.17	234
6	2.25	5.02	4.37	4.90	8.35	11.00	.375	28	5.71	6.22	667
8	2.63	6.91	5.24	6.77	10.51	13.50	.375	50	7.56	7.87	1404
10	2.67	8.74	7.24	8.70	12.48	15.50	.375	63	9.53	10.23	1955
12	3.07	10.71	9.13	10.50	14.45	17.40	.375	93	11.50	12.20	3106

* Required to retain disc in valve body. If pipe I.D. exceeds maximum, use optional disc retainer.
Pressure to unseat (ΔP) in horizontal or vertical pipeline: less than 1 psi.

071 45° Ball Check Valve

Sizes 1 through 4 inch, ANSI Class 150

The unique construction of the Tuflin 45° ball check valve permits unobstructed flow through the valve as the ball rides in a 45° guide, out of the path of the media. The valve provides a large Cv coefficient. A tight seal against backflow is assured. It can be mounted horizontally or vertically with upward flow.

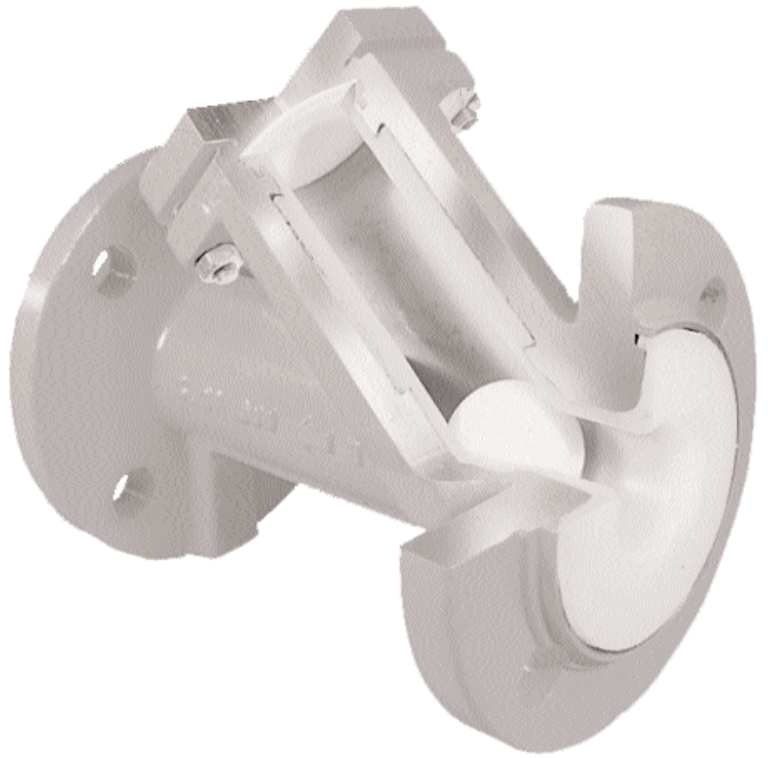

Materials Of Construction

Body	PFA lined ductile iron
Cover	Ductile iron
Diaphragm	PTFE
Ball	Glass-filled PTFE
Cover bolts	B7 Carbon steel

Pressure-Temperature Ratings

(Valves with PFA linings)

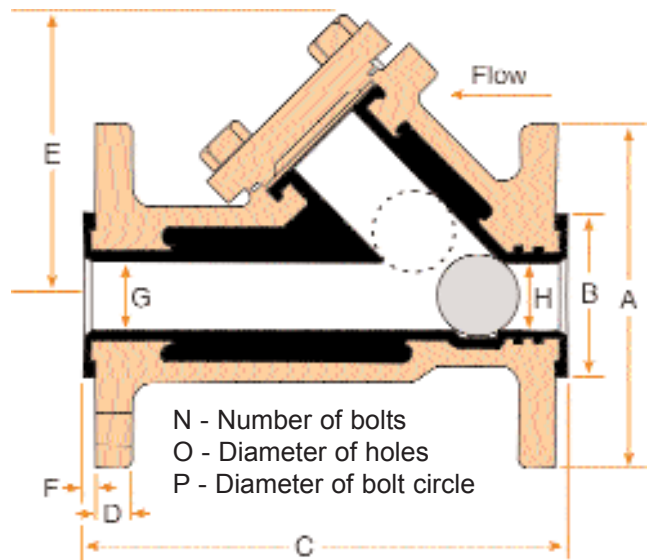
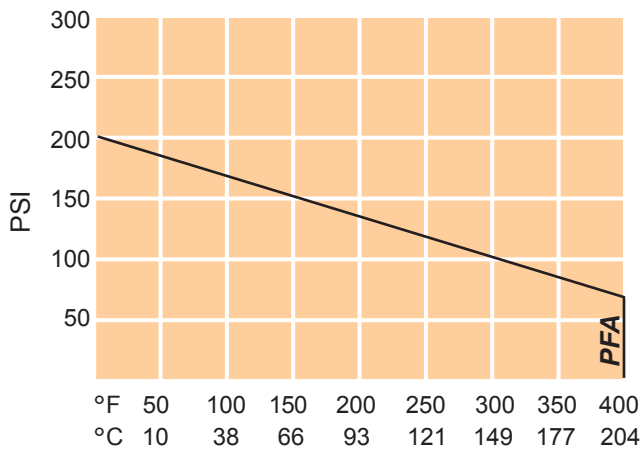

Maximum allowable $\Delta P = 200$ psi.

Cv Factors

Size	1	1½	2	3	4
	23	54	87	222	525

Dimensions (inches)

Size	A	B	C	D	E	F	G	H	N	O	P	Wt. lbs.	Approximate pressure (psi) to unseat (ΔP)		Approximate pressure (psi) to seat (ΔP)		Back pressure (psi) to seal (ΔP)	Allowable leakage rate @ 80 psi
													Horiz. pipe	Vert. pipe	Horiz. pipe	Vert. pipe		
1	4.25	2.00	6.00	.44	3.50	.13	.88	.78	4	.63	3.13	8	0	0	10	0	50	30 bubbles/minute
1½	5.00	2.88	7.00	.56	4.00	.13	1.25	1.13	4	.63	3.88	13	0	Less than 1 psi	20	0	50	60 bubbles/minute
2	6.00	3.63	8.69	.63	5.25	.13	1.63	1.63	4	.75	4.75	23	0	0	30	0	50	60 bubbles/minute
3	7.50	5.00	10.00	.75	6.38	.15	2.50	2.25	4	.75	6.00	42	0	0	50	0	50	60 bubbles/minute
4	9.00	6.18	13.78	.75	8.86	.27	3.74	3.70	8	.75	9.00	52	0	0	55	0	50	60 bubbles/minute

B202 Ball Check Valve

Formerly 072

Sizes 1/2 through 6 inch, ANSI Class 150

This valve can be installed in vertical pipe with upward flow. The patented ball seating design also provides for horizontal installation.*

Refer to page 18 for pressure-temperature ratings.

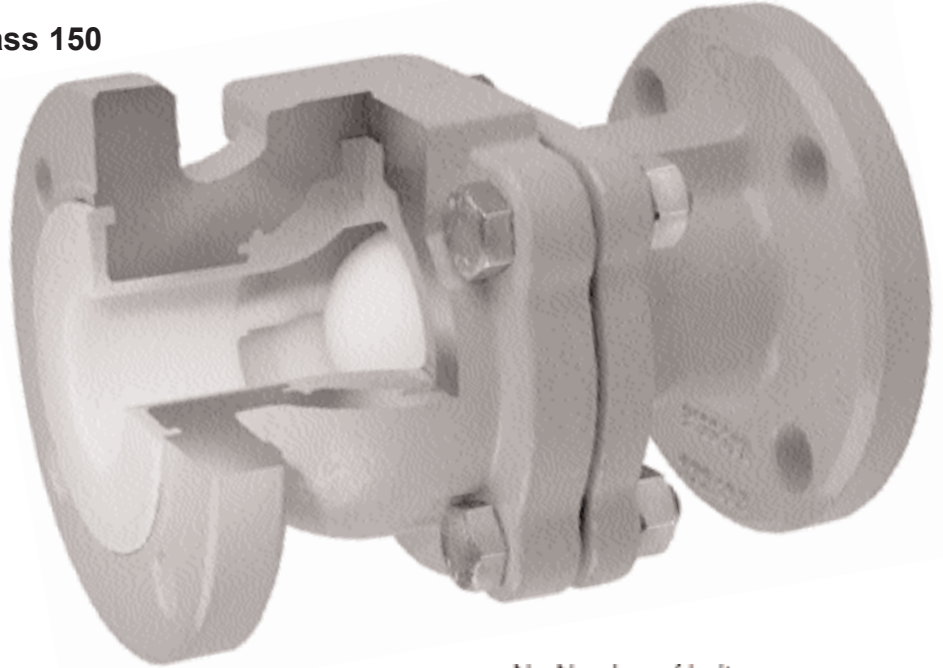

Materials of construction

Body	PFA lined ductile iron
Ball	Solid PTFE
Bolting	B7 carbon steel

Other lining materials available upon request.

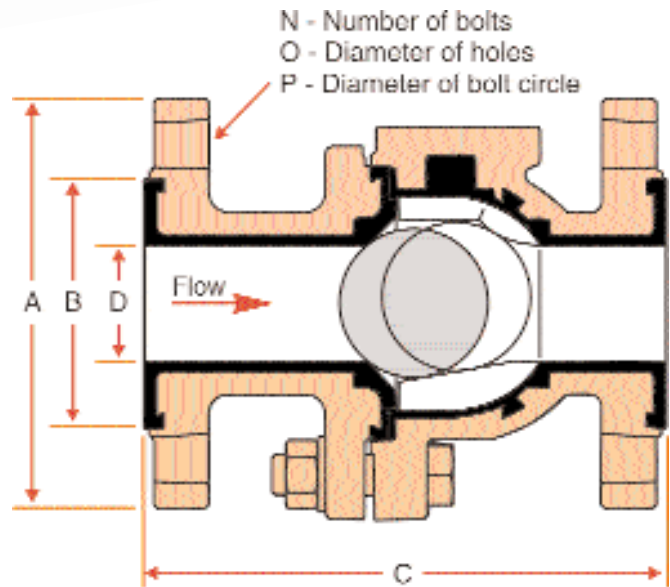

Dimensions (inches)

Size	A	B	C	D	N	O	P	Wt.lbs.	Opening Pressure Vertical Installation PSI	Cv Values
1/2	3.50	1.57	5.12	0.59	4	0.62	2.36	9	0.28	0.8
3/4	3.86	1.97	5.91	0.79	4	0.62	2.72	11	0.16	1.1
1	4.25	2.01	6.00	0.91	4	0.62	3.11	11	0.13	2.2
1 1/2	5.00	2.87	7.00	1.42	4	0.62	3.86	23	0.17	50
2	5.98	3.62	8.00	1.85	4	0.75	4.72	29	0.17	87
3	7.52	4.92	9.50	3.07	4	0.75	5.98	68	0.32	235
4	9.02	6.18	11.50	3.74	8	0.75	7.50	103	0.46	263
6	10.98	8.27	14.00	5.71	8	0.88	9.49	189	0.54	302

* U.S. Patent No. 5,971,015

C202 Piston Check Valve

Formerly 073

Sizes 1/2 through 12 inches, ANSI Class 150

Tufline lined piston check valves feature a spring loaded plug to provide an automatic seal against backflow. It is especially well suited for low pressure applications and can be installed in any orientation.

Refer to page 18 for pressure-temperature ratings.

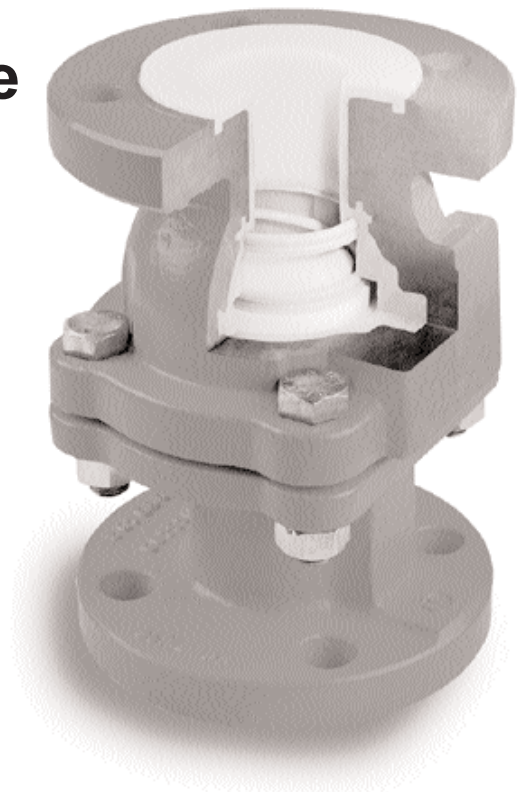

Materials of construction

Body	PFA lined ductile iron
Piston	PTFE
Piston holder	PTFE
Seat ring	PTFE
Spring	PTFE lined stainless steel
Bolting	B7 carbon steel plated

Other lining materials available upon request.

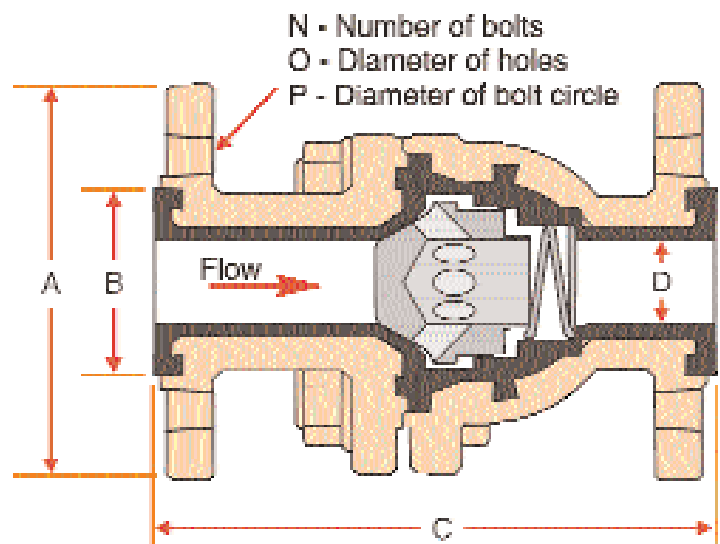

Dimensions (inches)

Size	A	B	C	D	N	O	P	Wt. lbs.	Opening Pressure Horizontal Position PSI	Opening Pressure Vertical Position PSI ↑	Opening Pressure Vertical Position PSI ↓	Cv Values
1/2	3.50	1.57	5.12	0.59	4	0.62	2.36	9	0.54	0.58	0.16	6.20
3/4	3.86	1.97	5.91	0.79	4	0.62	2.72	11	0.54	0.58	0.16	8.66
1	4.25	2.01	6.00	0.91	4	0.62	3.11	11	0.54	0.58	0.16	17.55
1 1/2	5.00	2.87	7.00	1.42	4	0.62	3.86	23	0.70	0.74	0.65	29.84
2	5.98	3.62	8.00	1.85	4	0.75	4.72	29	0.61	0.67	0.55	44.46
3	7.52	4.92	9.50	3.07	4	0.75	5.98	68	0.80	1.04	0.55	101.21
4	9.02	6.18	11.50	3.74	8	0.75	7.50	103	0.80	1.00	0.61	139.46
6	10.98	8.27	14.00	5.71	8	0.88	9.49	189	0.58	0.81	0.35	161.46

074 & 075 Poppet Check Valves

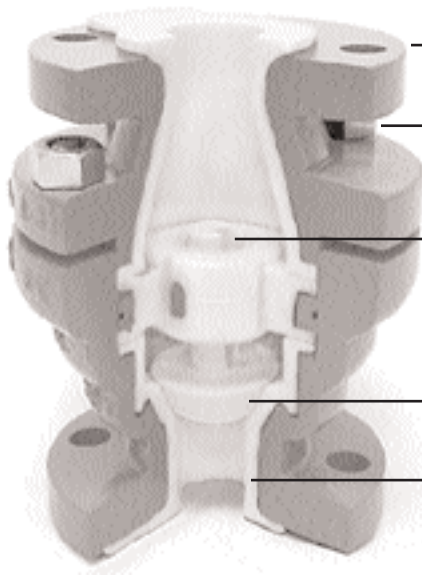

Figure 074

Ductile iron or cast steel bodies available.

B7 bolting resists chloride stress-cracking.

Keyway prevents poppet rotation.

Poppet covering matches body liner in 4" thru 8" sizes (solid PTFE poppet in 1" thru 3" sizes). Steel insert in 4" thru 8" valve poppet.

Choice of 3 liner materials (PP, PVDF, PFA) for handling a wide range of fluids.

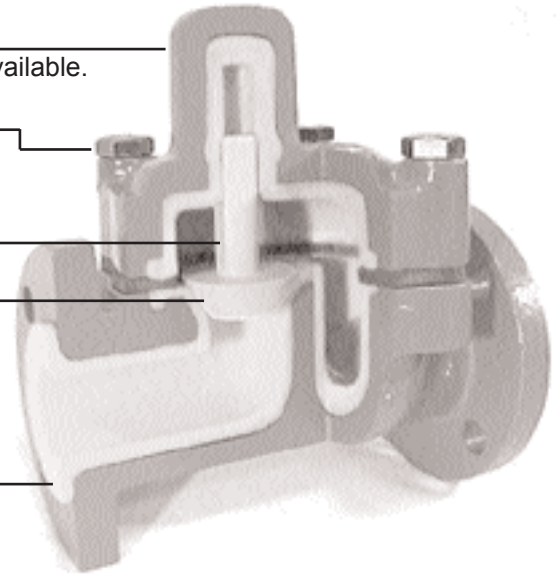

Figure 075

Tufline Plastic-Lined Poppet Check Valves handle various corrosive media at temperatures from -20°F to 300°F (-28°C to 149°C) by combining the best properties of two different materials of construction.

On the outside, a metal body provides strength, shock resistance, ease of installation, and a high pressure handling capability.

On the inside, a plastic lining offers corrosion resistance that stainless steel and high alloy metal valves can't match. The thick plastic lining also prevents contamination of high purity fluids.

Poppet-type check valves.

Horizontal and vertical check valves are plastic lined for handling corrosives and high-purity fluids. They are extremely effective in preventing back-pressure or backflow, featuring a low 0.5 psi (0.03 bar) cracking pressure differential, and are capable of handling pressures to 275 psi (19 bar).

Since Tufline Check Valves have only one moving part, they are less likely to need maintenance. Because every surface in contact with the fluid is made of, or covered with, a thick layer of plastic, corrosion and contamination are virtually eliminated. They also have full pipe diameter ports and provide minimal obstruction in the flow path. The poppet-type design eliminates problems that occur in some check valves with pockets that can trap fluid.

Pressure / temperature ratings

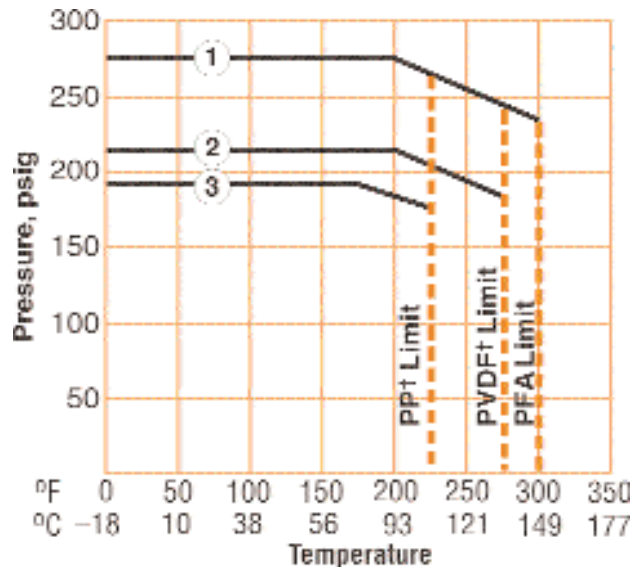

- ① Class 150 Cast Steel 1" - 4" Valves
- ② Class 150 Cast Steel 6" & 8" Valves
- ③ Class 150 Ductile Iron

† Maximum allowable temperature of liner/gasket may be lower based on the aggressiveness of the fluid being handled. Contact Xomox for further details.

Available size, body material, and lining combinations for both 074 and 075 valves

Size (in.)	1		1½		2		2½		3		4		6		8	
Body Material	DI	CS	DI	CS	DI	CS	DI	CS	DI	CS	DI	CS	DI	CS	DI	CS
PP	●	●	●	●	●	●	●	●	●	●	●	●	●	●	●	●
PVDF		●		●		●				●		●		●		*
PFA		●		●		●				●		●				

*Vertical Check Valve (074) only

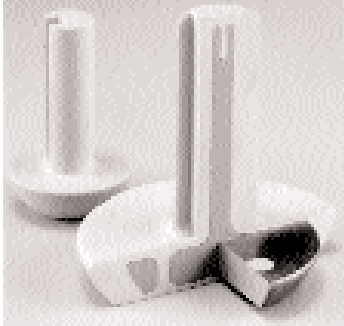

Poppets.

Valves 1" through 3" sizes feature a solid PTFE poppet. Larger sizes use a steel reinforced poppet molded of the same material as the valve liner.

Cv Factors

Size	Horizontal	Vertical
1	5	8
1½	22	60
2	30	130
2½	N/A	N/A
3	80	320
4	150	500
6	450	1100
8	800	1500

Body bolting torques.

To ensure optimum performance in the presence of thermal cycling, it is essential that the body nuts be torqued to the values shown in the table below.

Torquing should only be done on the system in the ambient, cooled state, never at elevated temperature. Otherwise, excessive force could be applied to the plastic faces. Xomox recommends retorquing body bolts immediately before installation of the valve.

Body bolt torque values (ft-lbs)

Size	Horizontal		Vertical
	Elastometric gaskets	PTFE gaskets	
1	30	30	35
1½	30	30	35
2	30	40	45
2½	30	N/A	60
3	55	120	60
4	40	60	50
6	65	110	75
8	80	125	120

Check valve dimensions & weights (All dimensions in inches)

		1	1½	2	2½	3	4	6	8
A	Horizontal Face To Face	7.00	7.63	8.63	8.88	10.75	14.50	18.50	23.13
A	Vertical Face To Face	6.38	7.13	8.13	8.50	9.75	12.00	14.50	17.13
B	Horizontal Center To Top	4.38	5.38	6.50	7.38	8.63	11.00	15.25	18.44
B	Vertical Center To Top	5.38	5.63	6.75	7.00	8.38	9.75	12.75	16.20
C	Flange Thickness	.44	.56	.63	.663	.75	.94	1.00	1.13
D	Plastic ID (PP, PVDF)	.69	1.25	1.63	2.09	2.69	3.50	5.56	7.25
D	Plastic ID (PFA)	.69	1.31	1.75	N/A	2.81	3.69	N/A	N/A
N	No. Of Bolt Holes	4	4	4	4	4	8	8	8
O	Size Of Bolt Holes	.63	.63	.75	.75	.75	.75	.88	.88
P	Bolt Circle Diameter	3.20	3.88	4.75	5.50	6.00	7.50	9.50	11.75
G	Flange Diameter	4.20	5.00	6.00	7.00	7.50	9.00	11.00	13.50
J	Face Diameter	1.88	2.69	3.44	3.94	4.63	5.94	8.00	10.06
K	Horizontal Approx. Weight, lbs.	15	19	31	37	56	92	200	330
K	Vertical Approx. Weight, lbs.	16	19	31	38	52	88	142	225

NA=Not Available

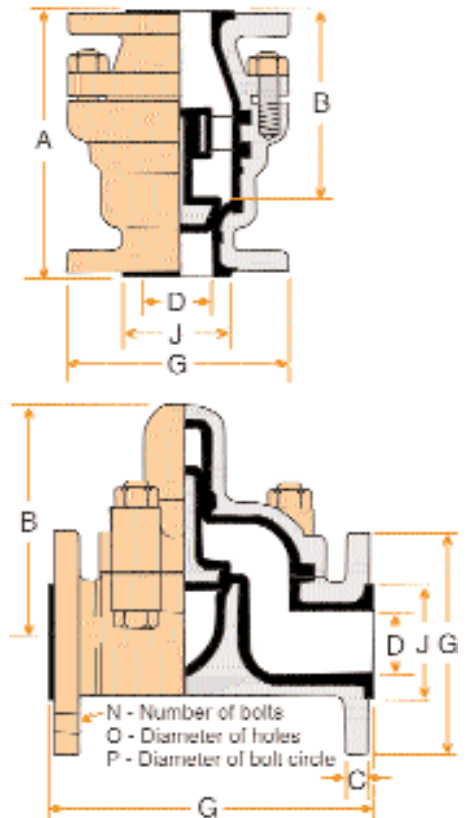

081 Sight Flow Indicator

Sizes 1 through 6 inch, ANSI Class 150

Tuflin sight flow indicators provide reliable indication of flow on any corrosive service. Safe and shatter-proof, each window consists of two tempered lime glasses cemented together by a proprietary adhesive. The glasses are encased with a steel circumferential band. Fluid flow can be viewed from either top or bottom. Drip-lip feature is incorporated into the liner for immediate flow indication on low-pressure applications.

Pressure-Temperature Ratings

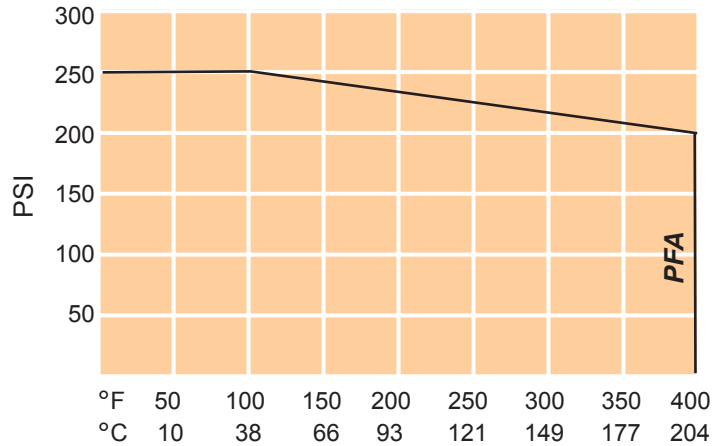

Materials of construction

Body	PFA lined ductile iron
Top and bottom covers	Ductile iron
Top and bottom seal discs	PFA
Top and bottom glass cushions	PTFE
Cover bolts and nuts	B7 carbon steel
Indicator rod support	PTFE
Indicator rod	PTFE
Top and bottom lens assembly	Tempered glass

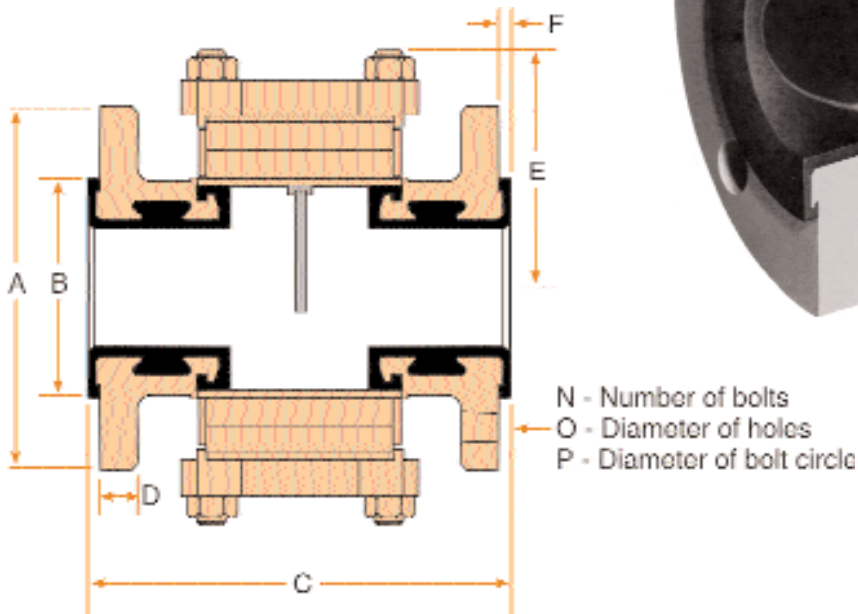
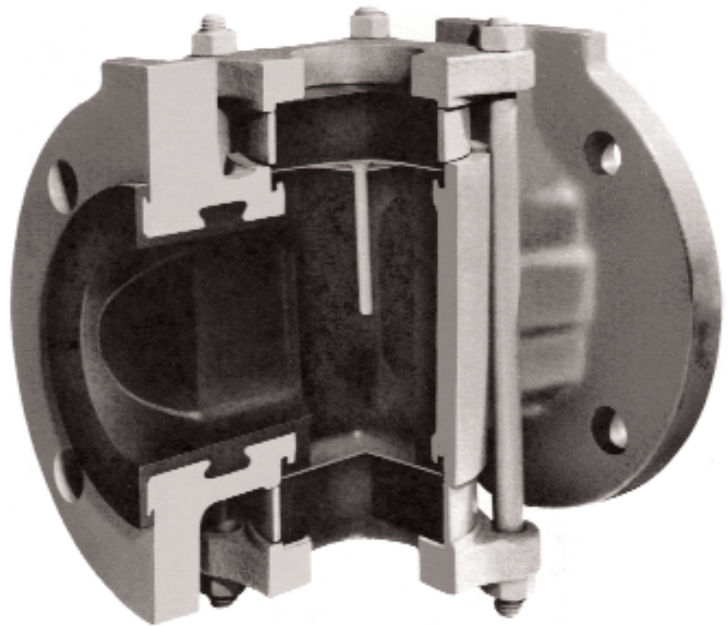

Dimensions (inches)

Size	A	B	C	D	E	F	N	O	P	Wt. lbs.	Cv Factors
1	4.25	2.88	5.00	.44	2.88	.13	4	.63	3.13	8	39
1½	5.00	3.25	6.50	.56	3.25	.13	4	.63	3.88	13	80
2	6.00	4.00	7.00	.63	4.00	.15	4	.75	4.75	20	155
3	7.50	4.50	8.00	.75	4.50	.15	4	.75	6.00	30	265
4	9.00	5.25	9.00	.94	5.25	.15	8	.75	7.50	50	493
6	11.00	5.69	10.50	1.00	5.69	.15	8	.88	9.50	84	967

F202 Basket Filter

Formerly **083**

Sizes 1/2 through 6 inch, ANSI Class 150

Tufline fully lined basket filters are used in a variety of corrosive services for the removal of debris from the pipeline or solid particles from the media.

Refer to page 18 for pressure-temperature ratings.

Materials of construction

Body	PFA lined ductile iron
Filter	PTFE
Bolting	B7 Carbon steel

Other lining materials available upon request.

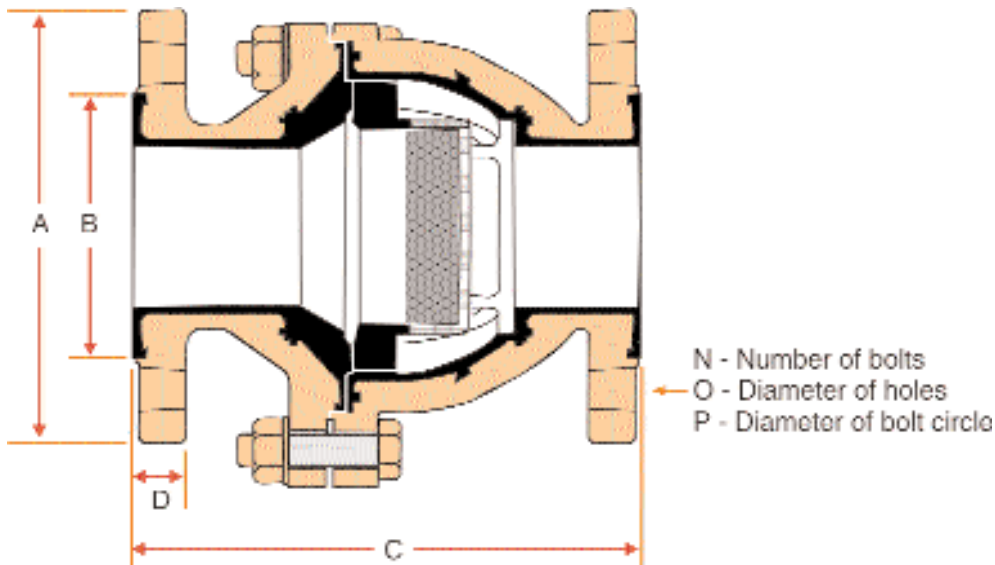
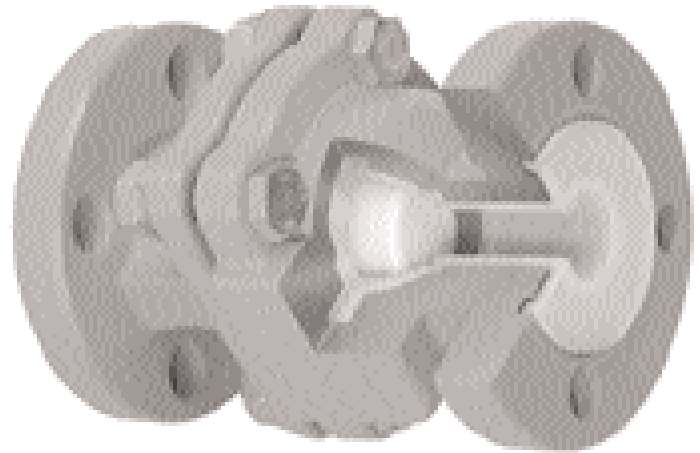

Dimensions (inches)

Size	A	B	C	D	N	O	P	Wt. lbs.	Opening Pressure Vertical Installation PSI
1/2	3.50	1.57	5.12	0.59	4	0.62	2.36	9	0.28
3/4	3.86	1.97	5.91	0.79	4	0.62	2.72	11	0.16
1	4.25	2.01	6.00	0.91	4	0.62	3.11	11	0.13
1 1/2	5.00	2.87	7.00	1.42	4	0.62	3.86	23	0.17
2	5.98	3.62	8.00	1.85	4	0.75	4.72	29	0.17
3	7.52	4.92	9.50	3.07	8	0.75	5.98	68	0.32
4	9.02	6.18	11.50	3.74	8	0.75	7.50	103	0.46
6	10.92	8.27	14.00	5.71	8	0.88	9.49	189	0.54

Y102 Y Strainer

Formerly **084**

Sizes 1/2 through 4 inches*, ANSI Class 150

Tufline Y strainers are used in a variety of corrosive services for the removal of debris from the pipeline or solid particles from the media. The unique design allows the strainer to be easily removed for cleaning or replacement.

Refer to page 18 for pressure-temperature ratings.

Materials of construction

Body	PFA lined ductile iron
Filter	PTFE
Flange cover	PFA lined steel
Cap	PTFE lined steel

Other lining materials available upon request.

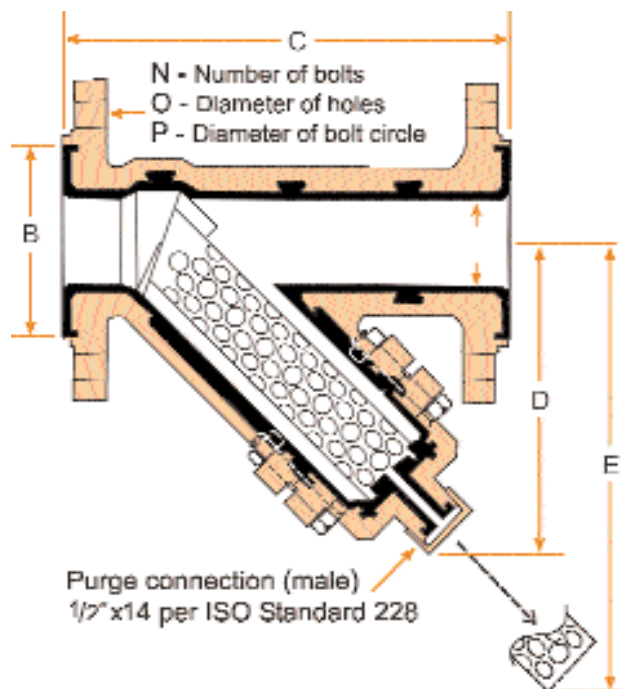
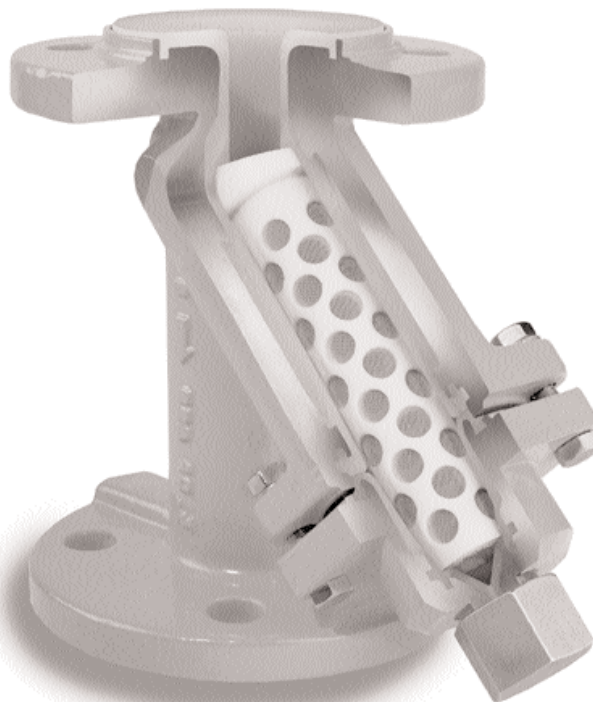

Dimensions (inches)

Size	B	C	D	E	N	O	P	Wt. lbs.	Cv Factors
1/2	1.57	5.91	3.94	5.2	4	0.62	2.36	8.14	0.23
3/4	2.24	5.91	3.94	5.2	4	0.62	2.72	8.14	0.25
1	2.60	6.30	4.09	5.5	4	0.62	3.11	9.46	6.13
1 1/2	3.43	7.87	5.63	7.1	4	0.62	3.86	17.38	13.87
2	3.94	9.06	6.34	9.5	4	0.75	4.72	22.00	23.81
3	5.35	12.20	10.08	13.4	8	0.75	5.98	43.56	49.48
4	6.18	13.78	11.18	16.5	8	0.75	7.50	58.30	93.17

*Other sizes on request.

085 PTFE Clamp Valve

Tufline Plastic-Lined

Clamp Valves handle varieties of corrosives at temperatures from -20°F to 400°F (-28°C to 204°C) by combining the best properties of two different materials of construction.

On the outside, a metal body provides strength, shock resistance, ease of installation, and a high pressure handling capability.

On the inside, the PTFE tube offers corrosion resistance that stainless steel and high alloy metal valves can't match.

The Teflon® PTFE Clamp Valve with its full-flow, straight-through packless design, is capable of bubble-tight shutoff and fine throttling. These features coupled with minimum maintenance and unexcelled corrosion resistance, makes the PTFE clamp valve the most economical valve available for tough CPI applications.

The clamp valve consists of a flexible PTFE tube and a clamp. Unlike pinch valves, the tubing is never kinked, creased or pinched. PTFE Clamp Valves are available in sizes 1" through 8" in various configurations and with a number of optional accessories.

Because all wetted surfaces are PTFE, the clamp valves offer unsurpassed chemical resistance at temperatures up to 400°F (350°C) for 6" and 8" valves. The minimum burst pressure for sizes 1" through 8" at 70°F is 900 psi and at 400°F is 600 psi.

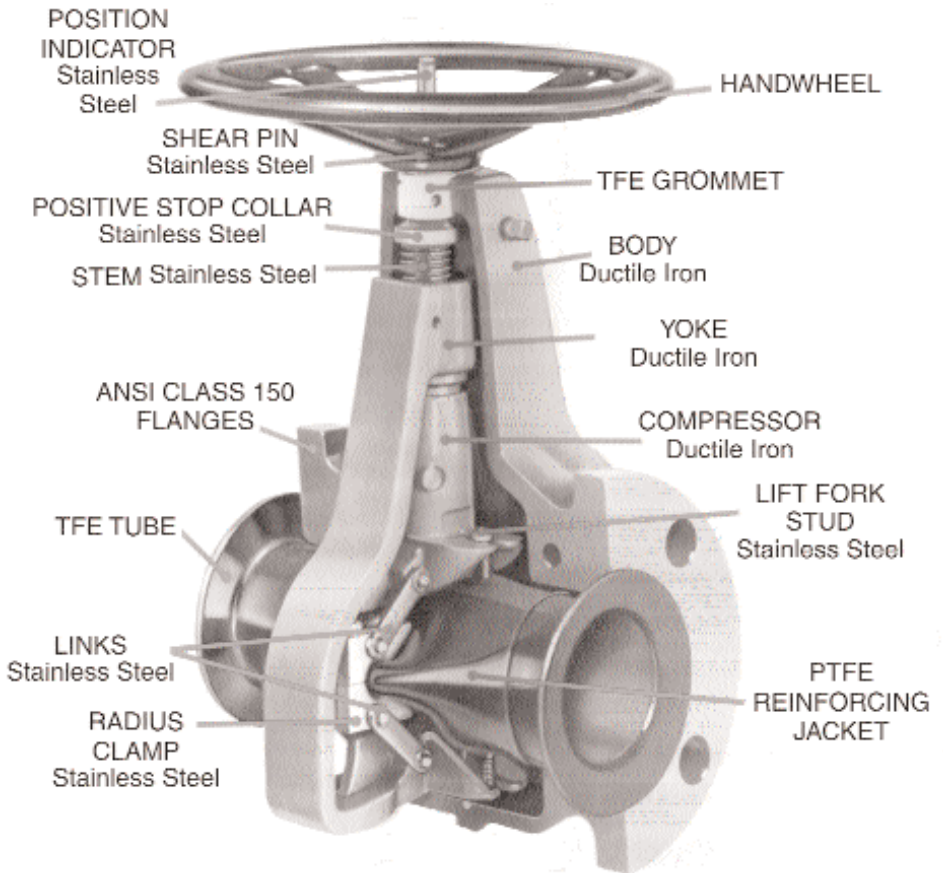

Pressure / temperature ratings

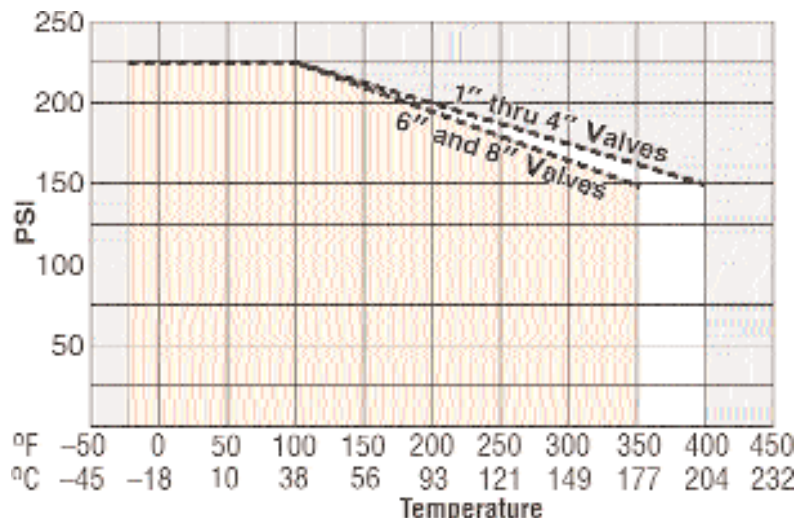

Note: Contact Xomox for applications beyond maximum nominal pressure and temperature ratings.

*Teflon® is a registered trademark of DuPont.

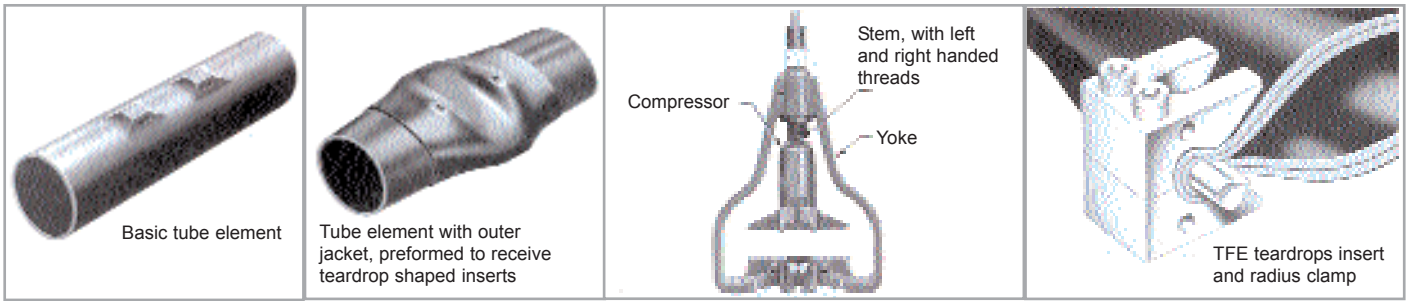

The Clamp valve is a flexible tube and a clamp. The tubing is made from Teflon PTFE.

A Teflon PTFE reinforcing jacket heat shrunk over the tube element increases strength without sacrificing flexibility.

The clamping mechanism consists of a compressor which travels down a stem with rotation of the hand-wheel or power operator, and a yoke which travels up the stem at the same time. Together these components clamp off flow bubble-tight.

Teflon inserts - teardrop shaped in cross section - on each side of the Teflon tube prevent the tube element from being overstressed. All flexing takes place on the center line of the valve between the teardrops, insuring long life for the valve.

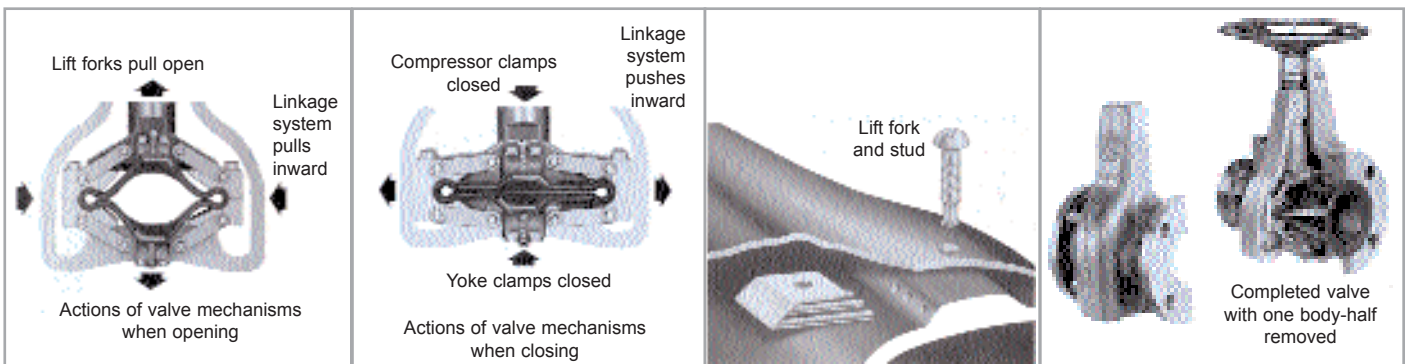

The radius clamps are connected to the yoke and to the compressor by means of links and link pins. These components, working together, provide a scissor-jack action which pushes the tube element inward during the opening cycle and pulls it outward during closing.

Four lift forks imbedded top and bottom in the tube element on each side of the clamp act as powerful fingers which work with the links and link pins to pull the sealing surfaces apart even under full vacuum conditions.

Operating parts are encased in a ductile iron body with Standard ANSI Class 150 flanges. Because the valve is symmetrical and completely bi-directional, either end can be placed upstream.

Pressure drop vs. flow at full open position for rotary operated valves.

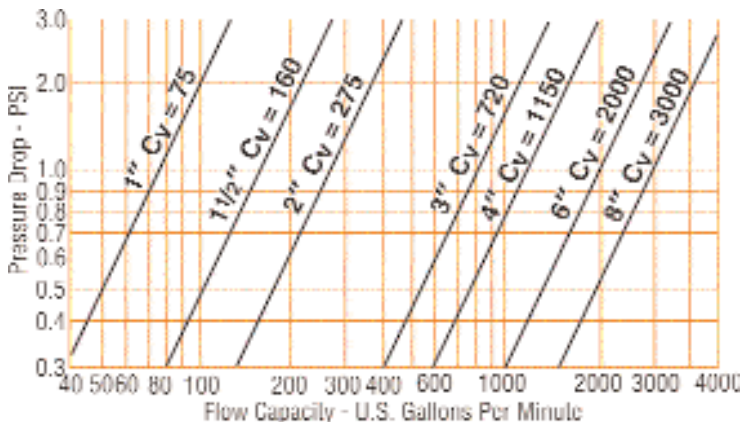

C_v is a coefficient which relates the rate of fluid flow through a valve to the pressure drop across the valve. Valves with higher values of C_v will provide higher rates of flow for a given pressure drop. C_v values for PTFE Clamp Valves are dependent upon inlet pressure. C_v values shown above were determined with inlet pressure of 65 psi or higher.

Valve sizing coefficient, C_v and liquid pressure recovery factor, F_L for linear valves.

Valve Size	C_v	F_L
1"	35	0.610
1 1/2"	112	0.420
2"	163	0.439
3"	396	0.330
4"	527	0.514

F_L is a coefficient which permits calculation of valve flow capacity at low inlet pressures.

$$F_L = \frac{q_{max.}}{C_v \sqrt{P_1 - r_c P_v}}$$

$$C_v = \frac{q}{\sqrt{\Delta P/G}}$$

C_v = Valve sizing coefficient
 q = Flow rate, gal/min
 ΔP = Pressure drop, psi.
 G = Specific gravity of fluid

F_L = Liquid pressure recovery factor
 $q_{max.}$ = Maximum flow rate
 C_v = Valve sizing coefficient
 P_1 = Valve inlet pressure, psi.
 P_v = Vapor pressure of fluid
 r_c = Critical pressure ratio

085 PTFE Clamp Valve Dimensions

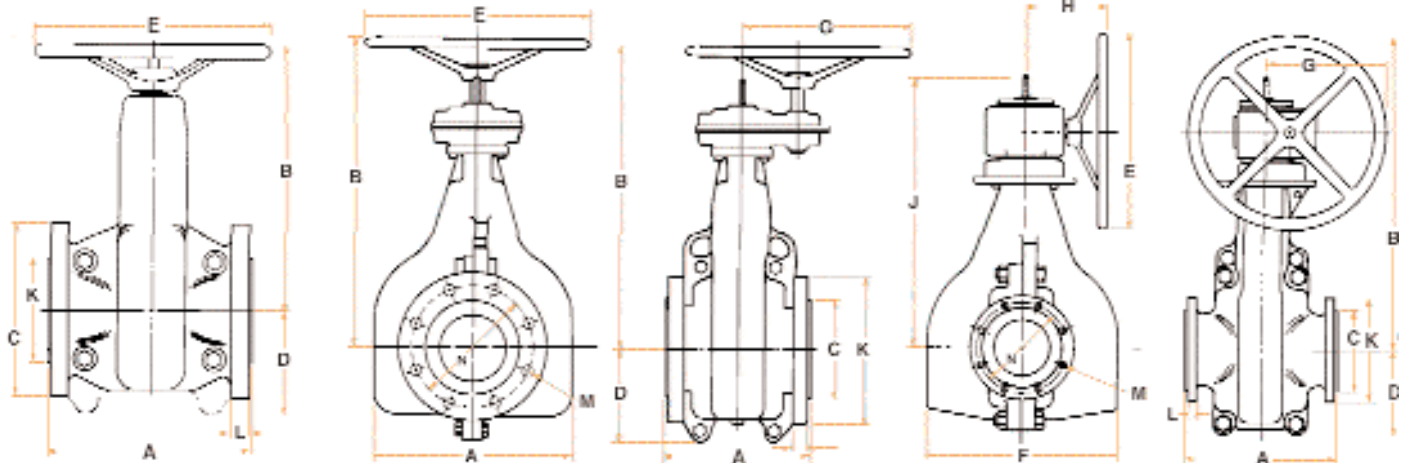

1" through 4"
Handwheel Operated

3" and 4"
Gear Operated

6" and 8" Valves

Valve Size	Face To Face	To Top Of Hand-Wheel	Flare Dia.	To Bottom Of Valve	Hand-Wheel Dia.	Width Of Body	To Extreme Edge Of Hand-Wheel	To Outside Face Of Hand-Wheel	To Top Of Position Indicator	Nominal Torque To Seat Ft. Lbs.	Wt. Lbs.	Flange Dimensions, 150 lb., ANSI				
												Flange Dia.	Flange Thick-ness	No. Of Bolt Holes	Bolt Hole Dia.	Bolt Circle Dia.
	A	B	C	D	E	F	G	H	J**			K	L		M	N
1	5.00	6.63	2.00	2.50	4.25	5.06	-	-	-	20	15	4.25	.44	4	.63	3.13
1½	6.50	8.06	2.88	-	7.00	6.69	-	-	-	30	27	5.00	.56	4	.63	3.88
2	7.00	9.19	3.63	-	8.00	7.38	-	-	-	35	35	6.00	.63	4	.75	4.75
3	8.00	14.88	5.00	4.50	14.00	10.88	-	-	-	65	75	7.50	.75	4	.75	6.00
3*	8.00	17.81	5.00	4.50	14.00	10.88	6.44	-	-	35	78	7.50	.75	4	.75	6.00
4	9.00	15.50	6.19	5.63	14.00	12.13	-	-	-	70	107	9.00	.94	8	.75	7.50
4*	9.00	18.44	6.19	5.63	14.00	12.13	10.44	-	-	50	113	9.00	.94	8	.75	7.50
6†	16.00	35.75	8.50	9.00	24.00	20.25	15.00	9.31	29.75	90	400	11.00	1.00	8	.88	9.50
6‡	16.00	35.75	8.50	9.00	24.00	20.25	15.00	9.31	29.75	125	400	11.00	1.00	8	.88	9.50
8†	19.00	35.75	10.63	9.00	24.00	20.25	15.00	9.31	29.75	100	430	13.50	1.13	8	.88	11.75
8‡	19.00	35.75	10.63	9.00	24.00	20.25	15.00	9.31	29.75	130	430	13.50	1.20	8	.88	11.75

Notes:

All flange bolt holes straddle the center lines.

All valve flange dimensions conform to ANSI B16.42. The face-to-face dimensions in valve sizes through 4" conform to ANSI B163.10, Class 150.

* Recommended in 3" size for line pressure over 150 psi and in 4" size for line pressure over 75 psi. An enclosed gear box is included.

** J is less than B on handwheel operated valves.

† Recommended for use with line pressure up to 75 psi, these models are furnished with 3-to-1 gear reducers.

‡ Recommended for use with line pressure over 75 psi, these models are furnished with 5-to-1 gear reducers.

K202 Tank Bottom Valve

Formerly 092

Sizes 1 through 6 inch, ANSI Class 150

Tufline lined tank bottom valves allow efficient discharge of corrosive fluids from bulk liquid tanks.

Refer to page 18 for pressure-temperature ratings.

Tank Connection Flange

The tank connection flange can be supplied in various sizes per the table below:

Output Size	Connection Size (inches)
1	1½ or 2
1½	2
2	3 or 4
3	4
4	6
6	8

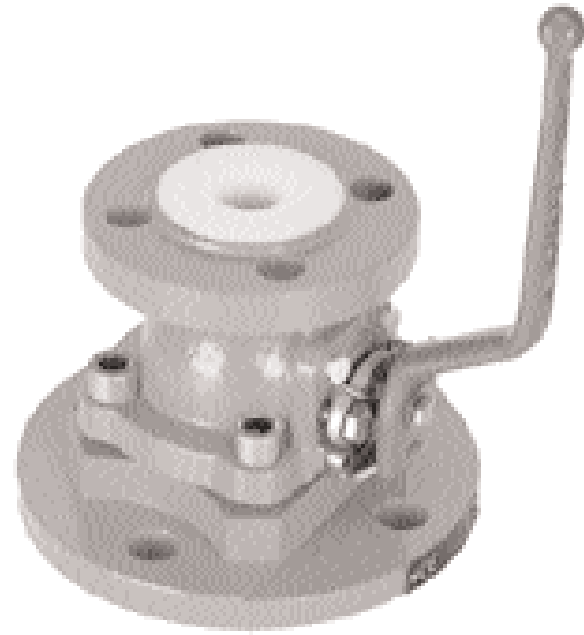

Materials of construction

Body	PFA lined ductile iron
Ball	PFA lined ductile iron
Stem	PFA lined stainless steel
Gland	Stainless steel
Handle	Cast ductile iron
Flange	PFA lined ductile iron
Bolting	B7 carbon steel
Stem packing	PTFE
Seat	PTFE

Other lining materials available upon request.

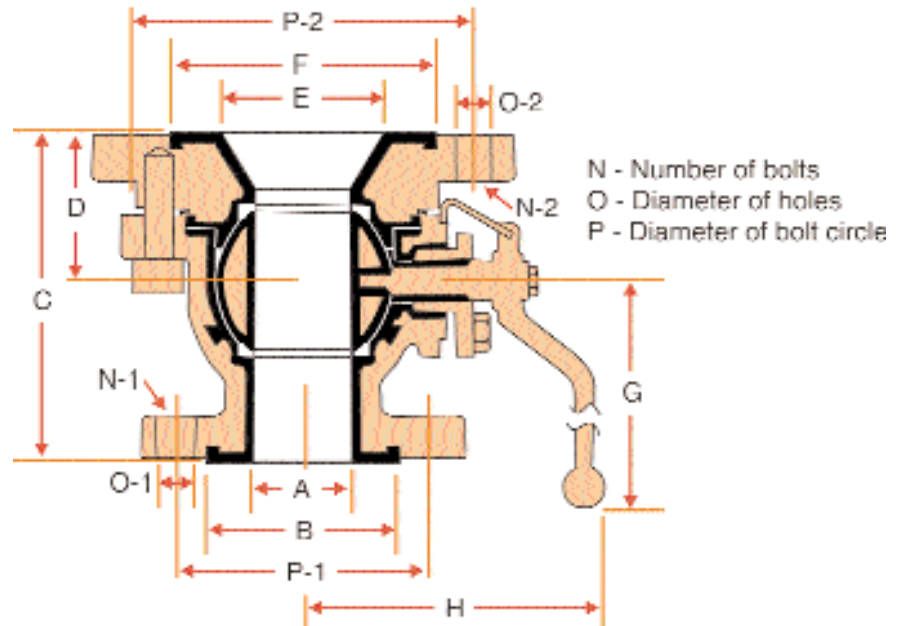

Size	A	B	C	D	E	F	G	H	N-1	O-1	P-1	N-2	O-2	P-2
1	1	2.01	4.80	2.44	1.50	2.87	6.61	4.53	4	0.75	3.13	4	0.63	3.87
1	1	2.01	4.80	2.44	2	3.78	6.61	4.53	4	0.75	3.13	4	0.74	4.74
1½	1.50	2.87	6.50	2.52	2	3.78	6.61	5.31	4	0.75	3.87	4	0.74	4.74
2	2	3.62	7.48	4.06	3	4.92	7.87	5.71	4	0.75	4.75	4	0.74	6.00
2	2	3.62	6.22	2.79	4	6.18	7.87	5.71	4	0.75	4.75	8	0.74	7.50
3	3	4.92	9.49	4.84	4	6.18	11.50	7.72	4	0.75	6.10	8	0.74	7.50
4	4	6.18	10.20	4.88	6	8.27	19.69	8.86	8	0.75	7.50	8	0.91	9.45
6	6	8.27	12.20	5.51	8	11.31	19.69	10.04	8	0.87	9.49	8	0.91	11.42

R40XL Short Face To Face Ball Valve

Formerly 093

Sizes 1½ through 3 inch, ANSI Class 150

Tuflin fully lined short face-to-face valves provide efficient, reliable service in corrosive applications where space is an important consideration.

Refer to page 18 for pressure-temperature ratings.

Actuation Torques

(Max. breakaway, inch-pounds)

Size	in/lb
1½	137
2	274
3	602
4	274

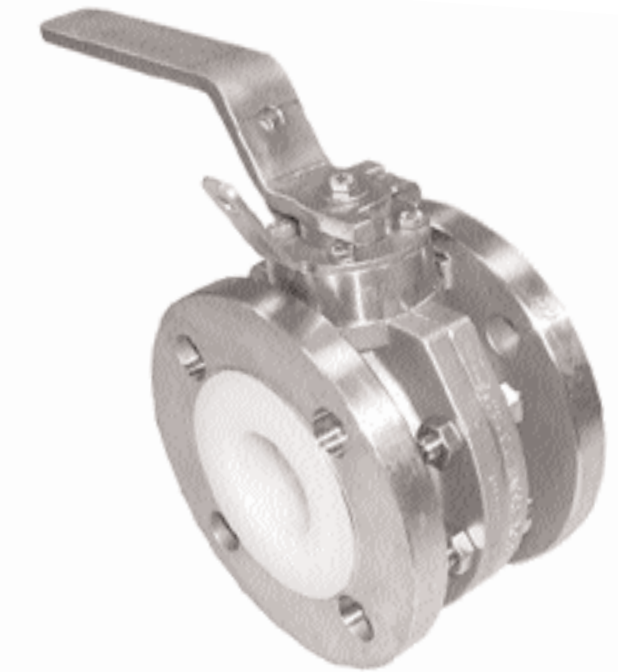
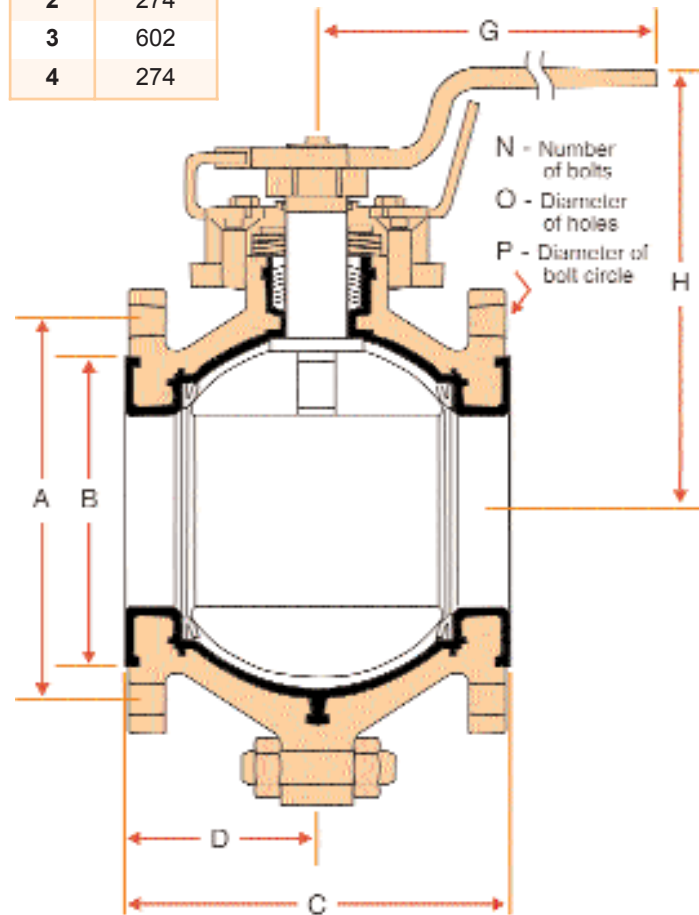

Materials of construction

Body	PFA lined stainless steel
Ball	PFA lined stainless steel
Stem	PFA lined stainless steel (CD4MCu)
Handle	Stainless steel
Fasteners	Stainless steel
Stem packing	PTFE
Seats	PTFE

Other lining materials available upon request.

Size	A	B	C	D	G	H	N	O	P	Wt. lbs.	Cv Values
1½	4.33	3.54	3.94	1.97	7.85	5.26	4	0.62	3.86	15	213
2	4.92	4.02	4.33	2.17	7.85	5.73	4	0.75	4.72	22	295
3	6.30	5.43	5.91	2.95	11.42	7.52	8	0.75	5.98	47	629
4	7.09	6.30	7.48	3.74	15.75	8.66	8	0.75	7.50	86	1395

How To Order

Specify to following:	Size,	Figure Number,	Material
Example	2",	071 Check Valve,	PFA Lined

Vacuum service

Tufline fully lined products perform well in vacuum service.

Oxygen and chlorine valves.

Valves designated for oxygen or chlorine service are thoroughly cleaned, tested, and dried per internal Xomox oxygen and chlorine standards. The flanges are then sealed and valves are packaged in plastic containers.

Quality assurance.

Tufline lined valves are used successfully in numerous applications throughout the chemical process industries. Xomox quality control procedures assure lining integrity, seat leak tightness, and absence of external leaks. Liners are dielectrically spark tested at 20,000 volts in accordance with ASTM D5162 specifications. Valves are available specifically tested and tagged to indicate conformity to ANSI B16.34 or B16.42 shell tests and MSS SP-61 seat test requirements.

Deviations from standard.

Certain products and components in this catalog may be obtained upon application in additional sizes and other than standard materials.

Products may also be supplied in special sizes and configurations from the Xomox Special Products Group. This group offers design, engineering, and manufacturing services for custom products.

Pressure-Temperature Ratings

(Valves with PFA linings)

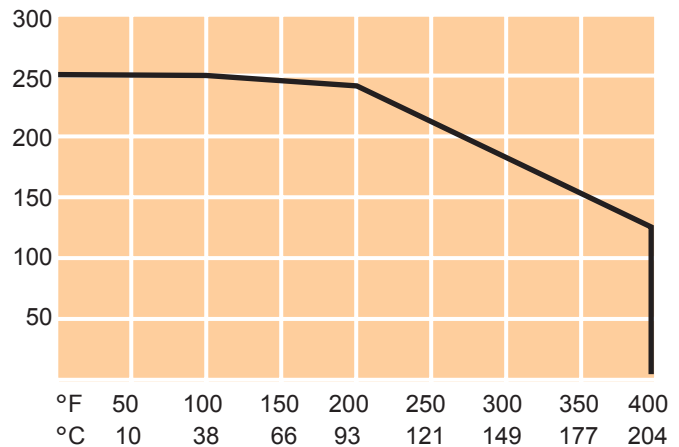

Xomox offers a broad range of lined valves.

For superior assured sealing, the metal-to-metal body joint of the Tufline Lined Ball Valve controls compression of the liner.

Tufline Lined Butterfly Valves have a continuous disc/shaft lining and a body lining that extends well beyond the secondary seal area.

Tufline Lined Plug Valves are an economical alternative to high alloy valves.

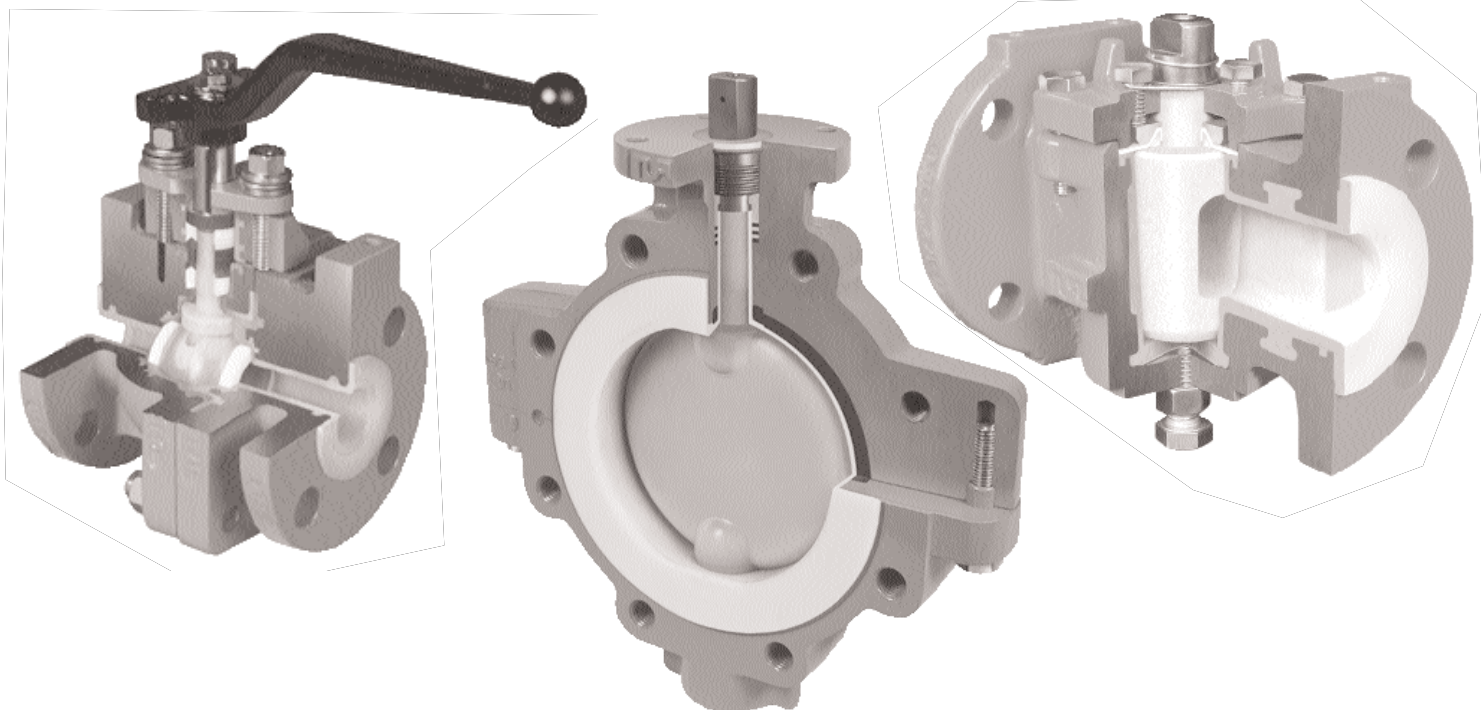

Single source responsibility for actuation and control.

Valves are available with Xomox XRP™ Actuators and Matryx® Vane Actuators.

Xomox switches and other control accessories are also available.

Let your regional Xomox Automation & Service Center take full responsibility for automation of your complete valve package.

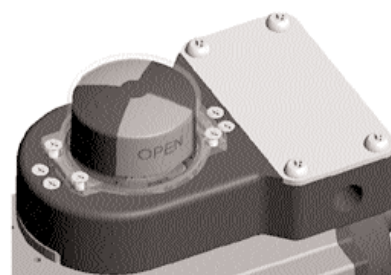
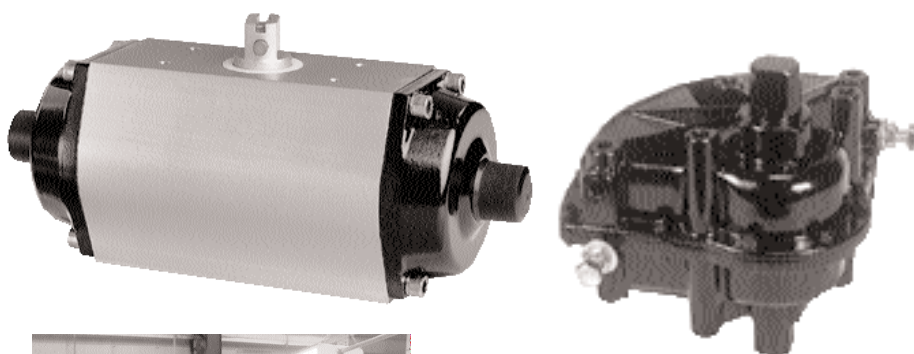

Global Capabilities For Global Customers

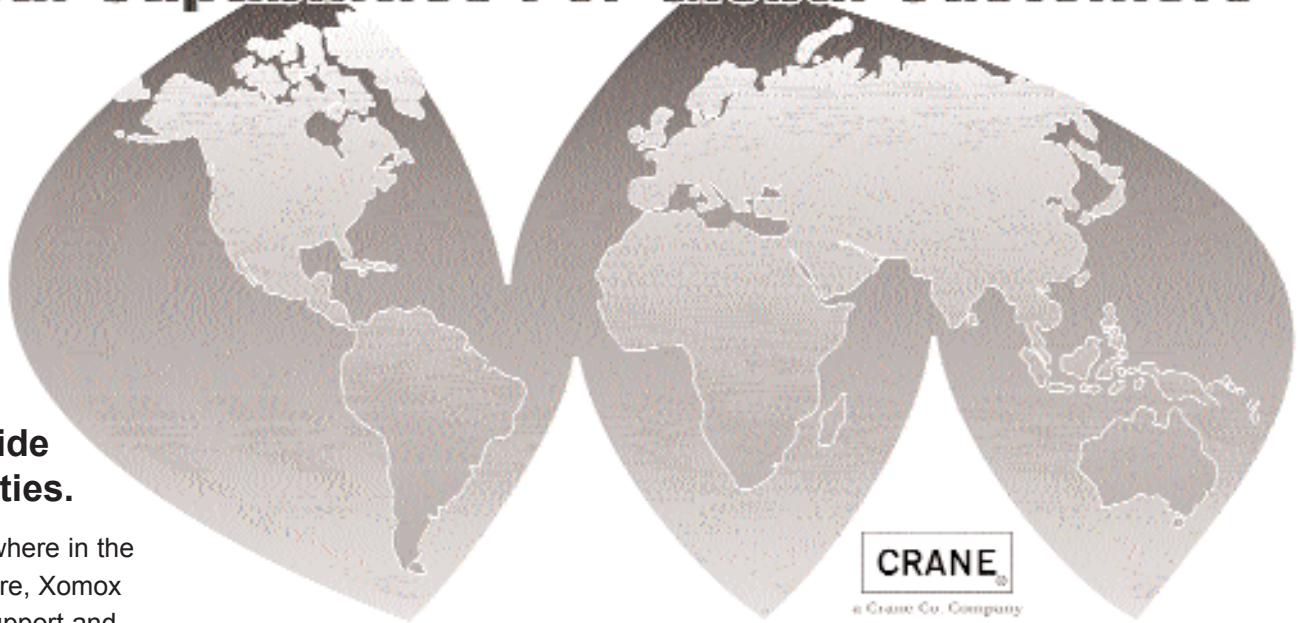

Worldwide capabilities.

No matter where in the world you are, Xomox technical support and services are available from:

- 16 Manufacturing Facilities
- 18 Service Centers
- 50 Sales Offices
- More than 200 Xomox Authorized Distributors

Product selection.

Xomox offers the broadest line of process valves, actuators, accessories, and related services including:

- Tufline® Process Valves
- Saunders® Diaphragm Valves
- Matryx® Rack & Pinion, Vane Actuators
- Xomox® XRP™ Actuators

Product responsibility.

Xomox's concern for product performance extends to the product's period of service. We feel it is important for users to also be aware of their responsibilities. Our products are manufactured and used in numerous applications with a wide variety of service conditions. While general guidelines are often furnished, it obviously is not possible to provide complete and specific performance data for every conceivable service condition.

Global locator.

For a listing of Xomox Manufacturing Facilities, Service Centers, Regional Offices, and Authorized Distributors, visit our web site www.xomox.com.

Xomox literature.

All Xomox catalogs and technical data are available as PDF files at www.xomox.com.

Phone support.

Call your nearest Xomox Sales Office or the Xomox World Headquarters:
Phone: 513-745-6000
Fax: 513-745-6093

Corporate strength.

Xomox is a Crane Co. company. Through the Crane Co. association, Xomox offers even greater global capabilities and breadth of product lines.

Xomox Corporation

World Headquarters
4444 Cooper Road
Cincinnati, Ohio 45242

XOMOX
Process Valves & Actuators

Therefore, the end user must assume final responsibility for proper evaluation, application and performance of all products. The contents of this document are presented for information purposes only. Every effort has been made to ensure accuracy. This information is not intended to be construed as warranties or guarantees, expressed or implied, nor imply use applicability, for products or services described herein.

We reserve the right to modify or improve the designs and specifications of such products at any time without notice. As the manufacturer, Xomox sells its products and services pursuant to its standard terms and conditions of sale, including its limited warranty, copies of which are available upon request. Xomox limits its liability specifically to the replacement or repair of defective items, or to a refund for same. Xomox does not accept liability for any incidental or consequential damages.